

GX120/160/200/240/270/340/390

Fuel System Inspection

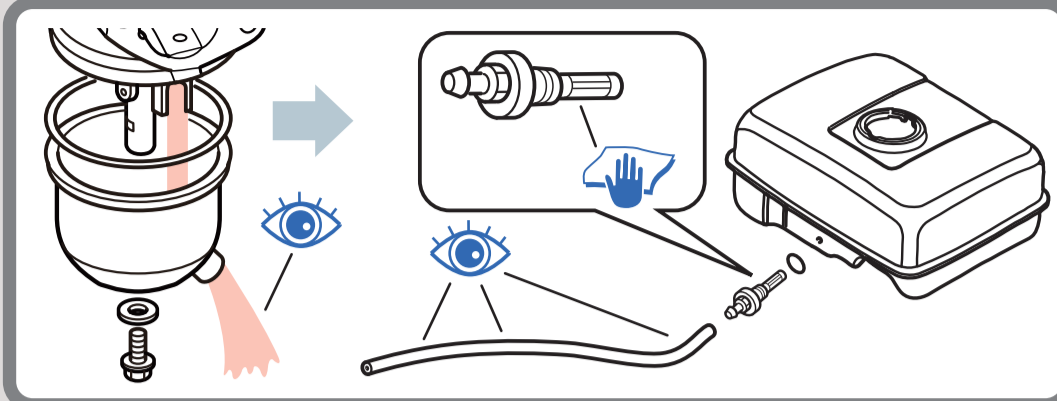

Compression System Inspection

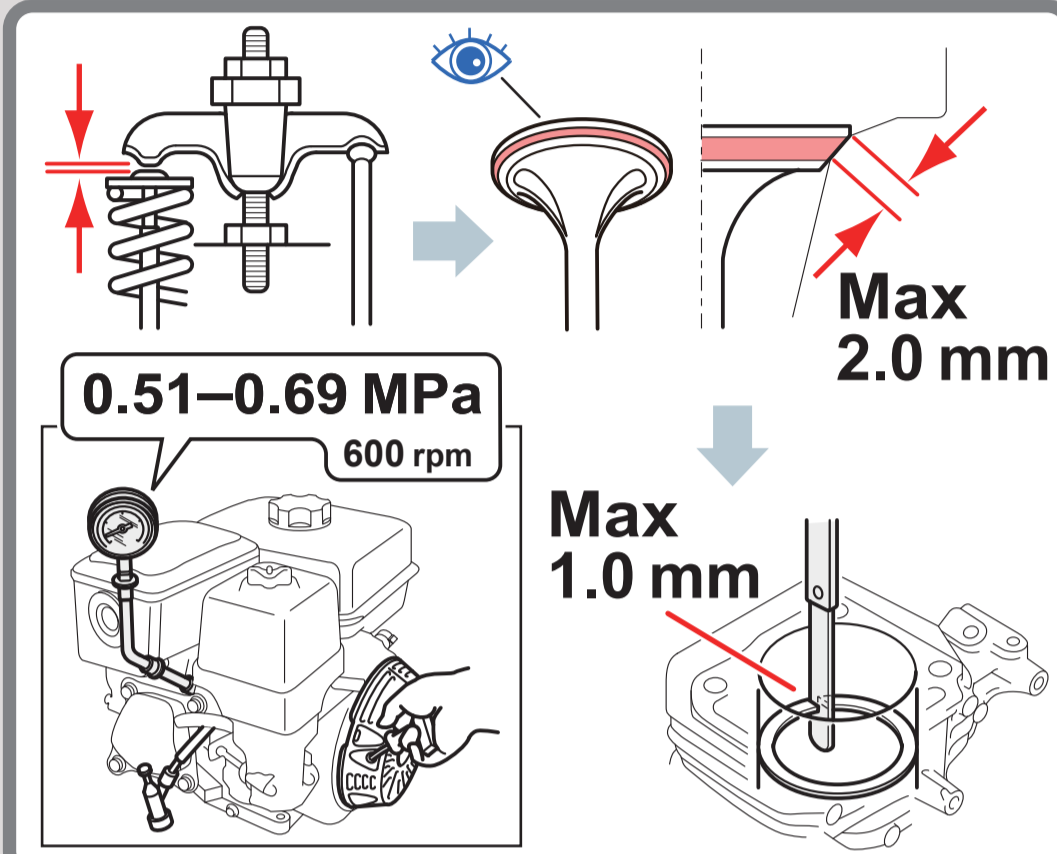

Ignition System Inspection

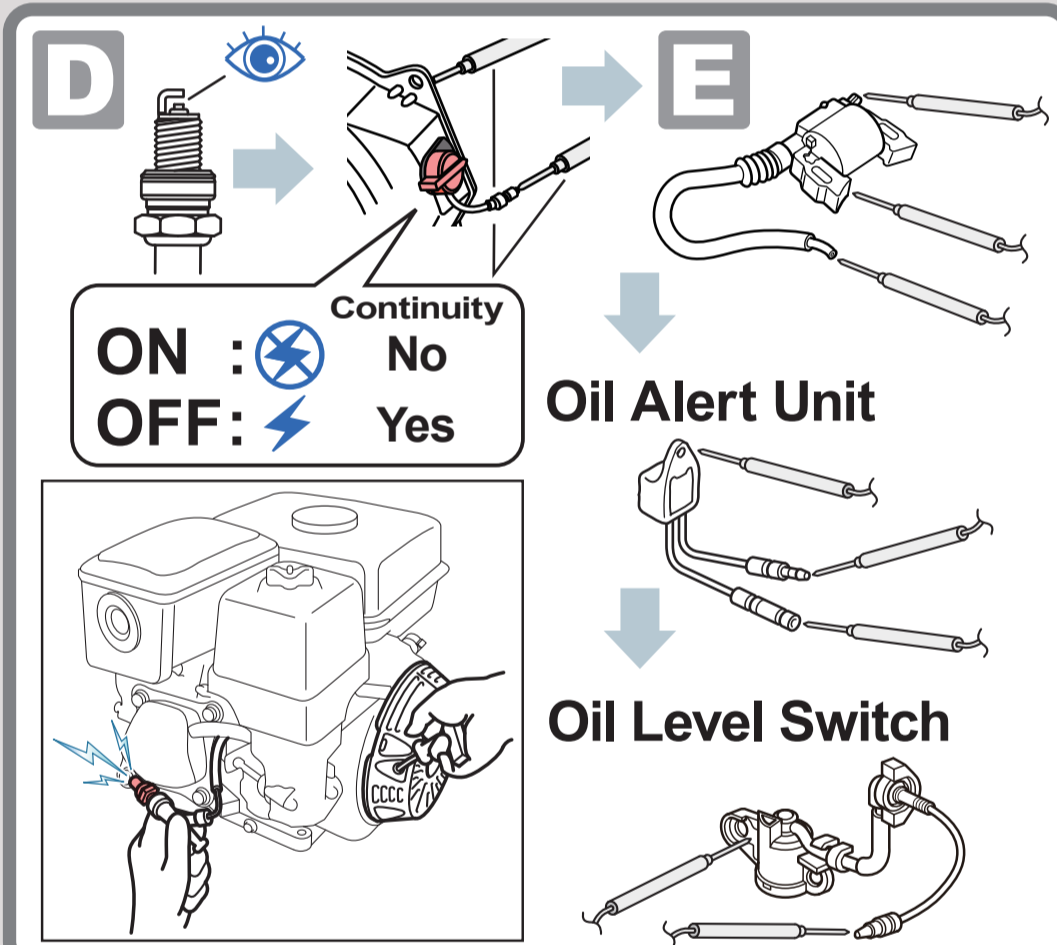

12 N·m (GX120)
24 N·m (GX160/200)
24 N·m**

24 N·m

10 N·m

10 N·m

2 N·m

5.4 N·m

12 N·m*
14 N·m**

18 N·m*
22.5 N·m**

75 N·m*
128 N·m (GX240/270)
170 N·m (GX340/390)

24 N·m

24 N·m*
35 N·m**

24 N·m

24 N·m*
35 N·m**

10 N·m

9 N·m

9 N·m

Specified Torque Values

Indication	Model
N·m	All
N·m*	GX120/160/200
N·m**	GX240/270/340/390

Governor System Assembly

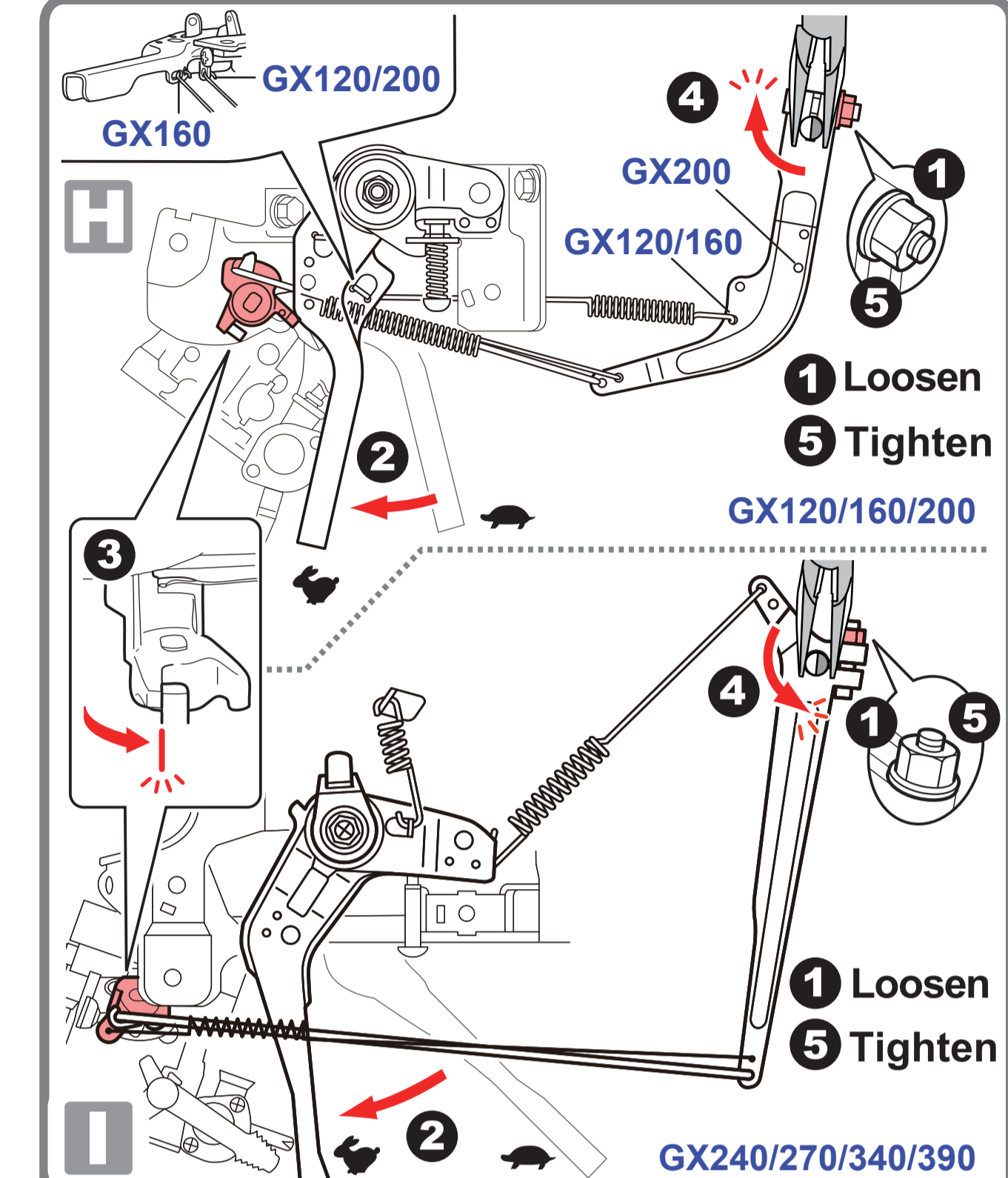

Valve Clearance Adjustment

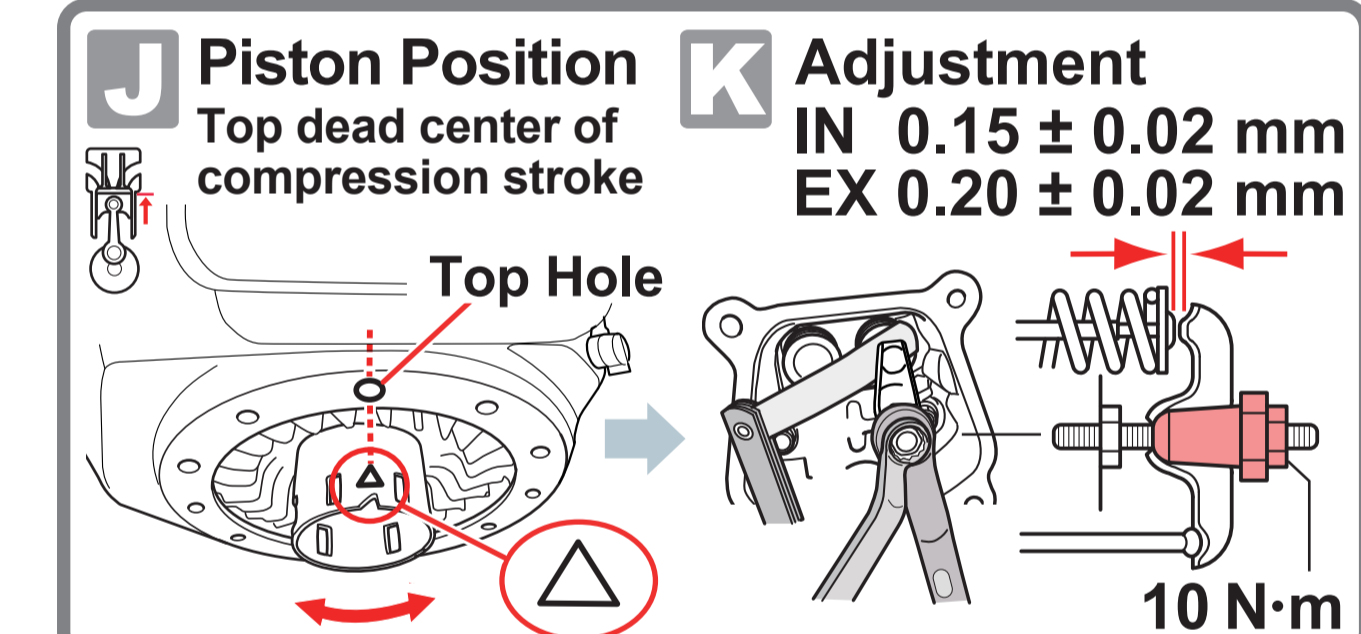

Engine Speed Adjustment

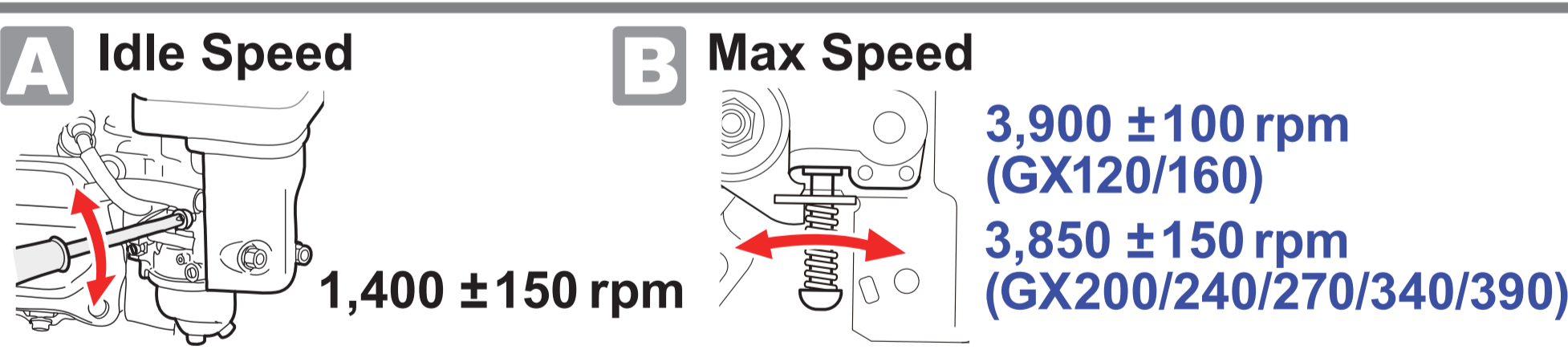

Ignition System Assembly/Adjustment

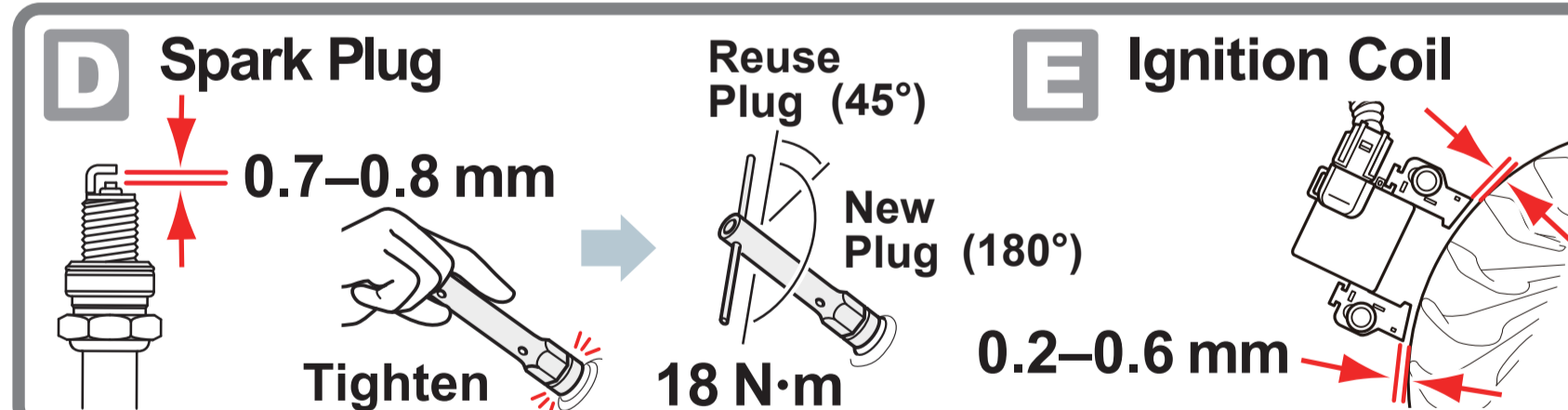

Piston Assembly/Installation

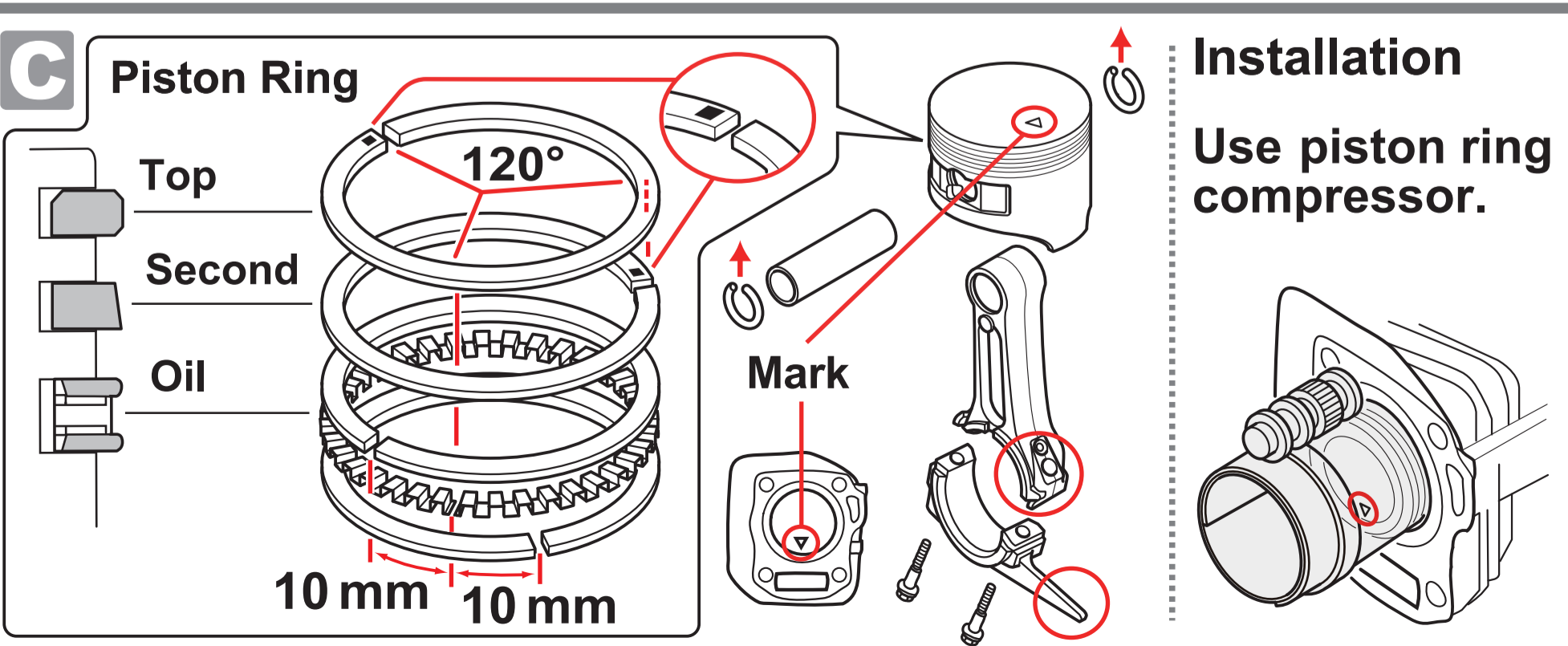

Camshaft Installation

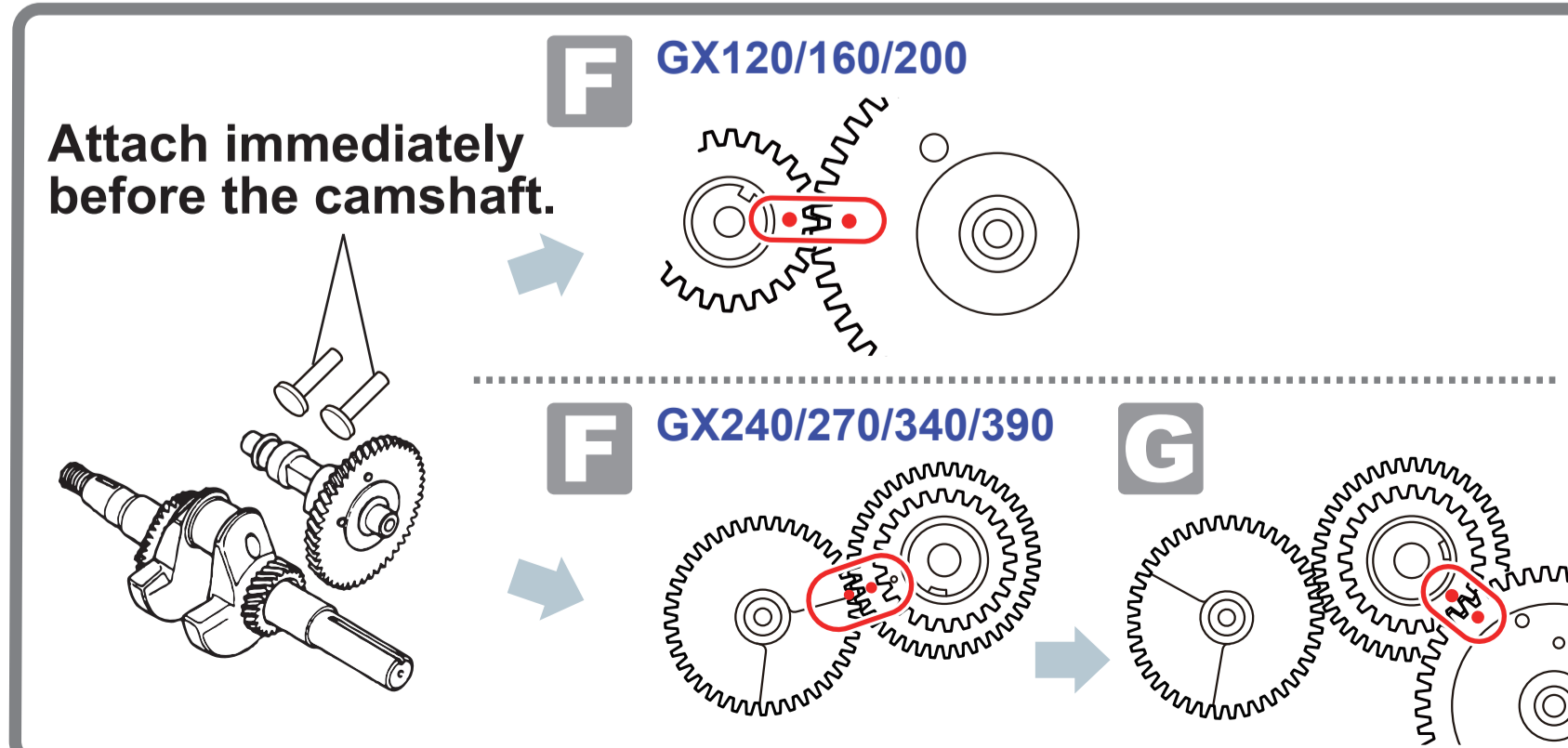

Flywheel Removal/Installation

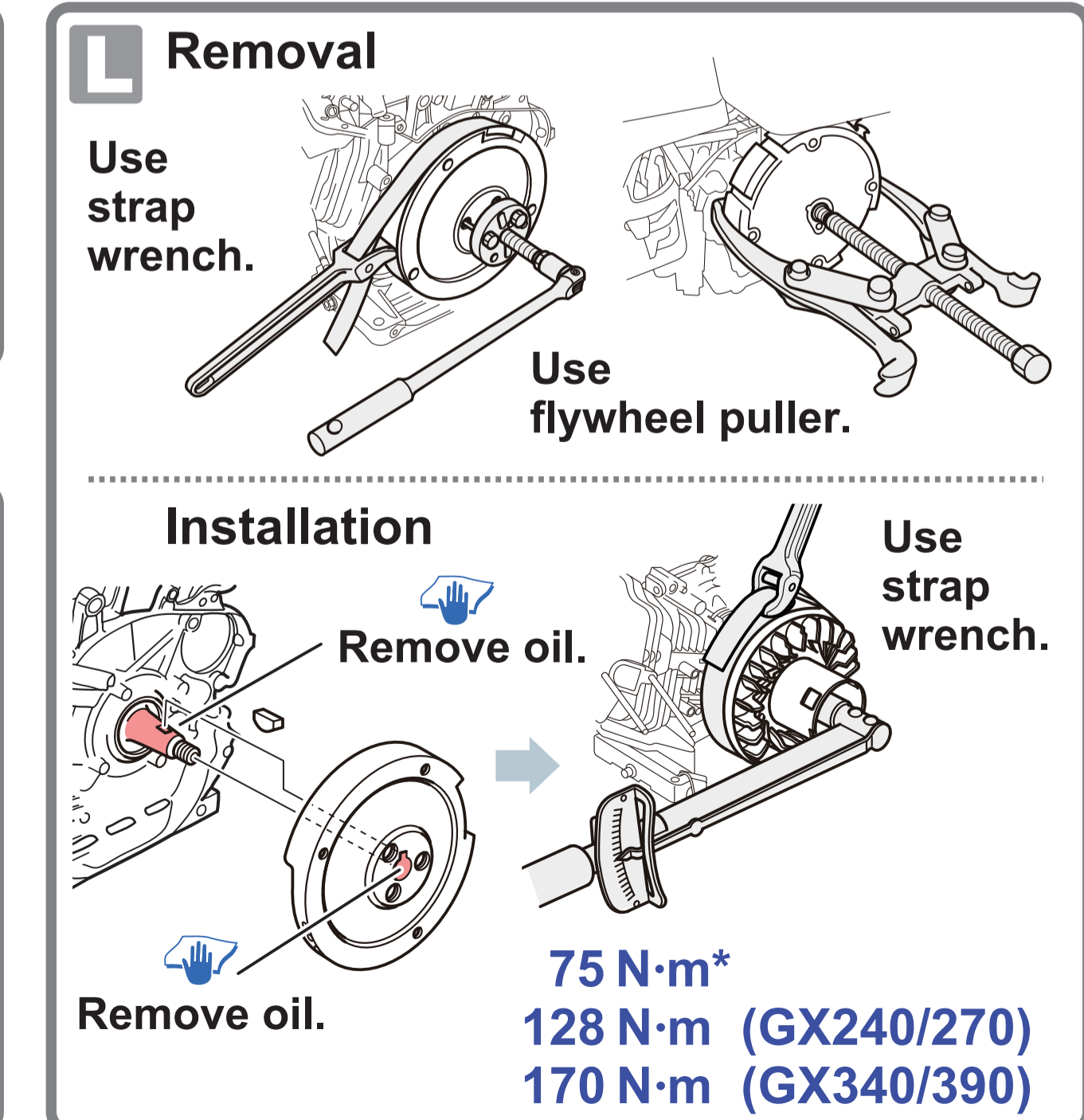

Standard Torque Values

Item	Size	Torque (N·m)
Bolt	M5	5.3
	M6	10
	M8	22
	M10	34
Nut	M12	54
	M5	5.3
	M6	12
Flange Bolt	M6	12
	M8	23
	M10	40
Flange Nut	M10	40
	M5	5.3
	M6	12
SH Bolt	M6	9.0
	M5	5.4
	M6	12
CT Flange Bolt	M4	2.1
	M5	4.3
	M6	9.0

- Fuel
- Compression
- Ignition
- Other